

# UL 5 - 12L

12V 5AH

STANDBY

# Ultracell®

'Quality in Every Language'

## Image



## Terminal Type

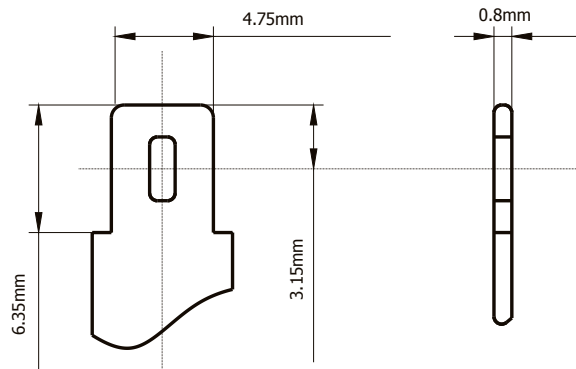

## Dimensions

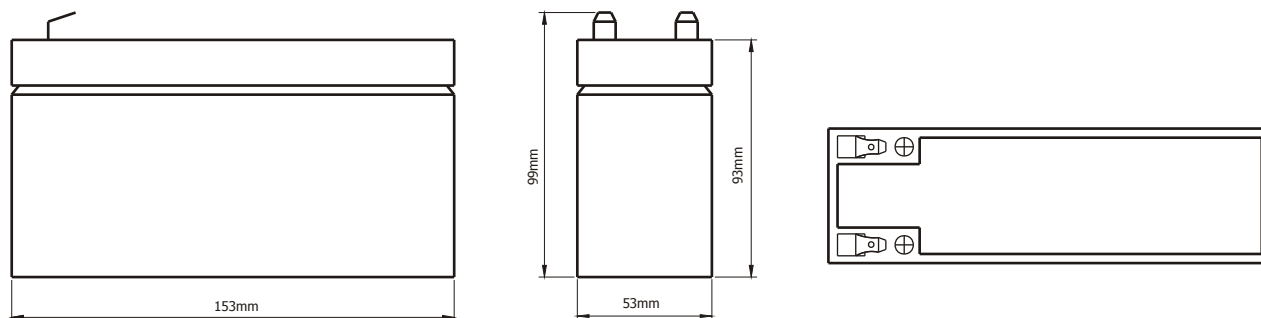

## Specifications

Battery Model	UL 5 - 12L			
Designed Floating Life	5 Years			
Capacity (25°C)	20HR (0.25A, 1.75V)	10HR (0.475A, 1.75V)	5HR (0.85A, 1.75V)	1HR (3.0A, 1.55V)
	5.0AH	4.75AH	4.25AH	3AH
Dimensions	Length	Width	Height	Total Height
	153mm	53mm	93mm	99mm
Approx. Weight	1.85Kg			
Internal Resistance	Fully Charged at 25°C 0.025 Ohm			
Self Discharge	3% of capacity declined per month at 25°C			
Capacity Affected by Temperature	40°C	25°C	0°C	-15°C
	102%	100%	85%	65%
Charge Voltage (25°C)	Cycle Use		Float Use	
	14.0-15.0V (-24mV/C), max. Current: 1.5A		13.6-13.8V (-18mV/C)	

## Construction

Component — Raw material  
 Positive — Lead dioxide  
 Negative — Lead  
 Container — ABS (Flame Retardent optional)  
 Cover — ABS (Flame Retardent optional)

Sealed and maintenance free option

Sealant — Epoxy Resin  
 Safety Valve — EPDR  
 Terminal — Copper  
 Separator — Fibre Glass  
 Electrolyte — Sulphuric acid

Non-spillable construction design



Tel +44 (0) 151 523 2777  
 Fax +44 (0) 151 523 0855  
 E-mail info@ultracell.co.uk  
 Web www.ultracell.co.uk

### Charge Characteristic

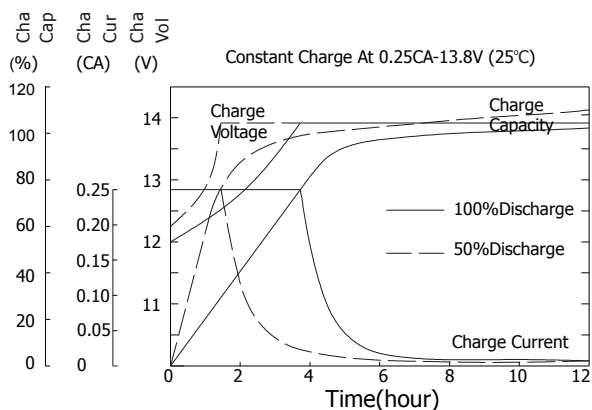

### Discharge Characteristic 25°C

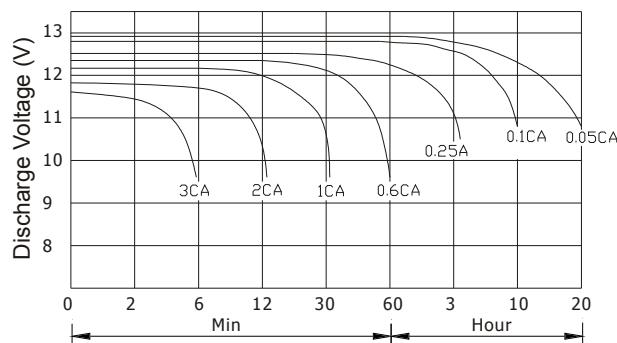

### Relationship of OCV and state of charge

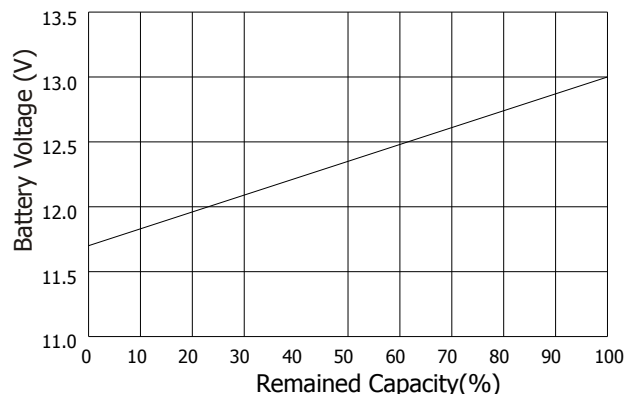

### Self Discharge Characteristics

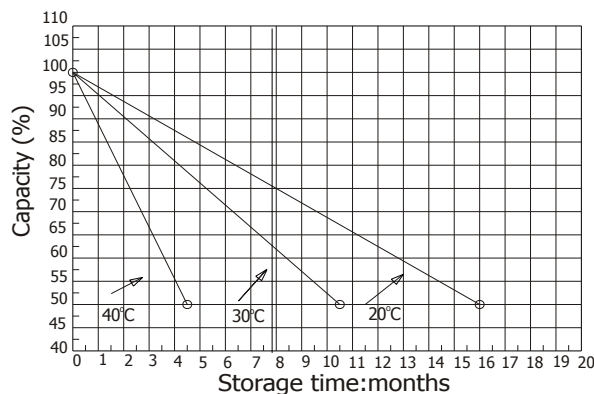

### Constant Current Discharge Ratings - amperes at 25°C

F.V / Time	5 MIN	10 MIN	15 MIN	30 MIN	1 HR	3 HR	5 HR	10 HR	20 HR
1.60 V	19.7	12.1	9.17	5.59	3.00	1.56	0.92	0.51	0.28
1.67 V	18.3	11.6	8.89	5.36	2.97	1.32	0.90	0.50	0.27
1.70 V	16.9	11.1	8.61	4.86	2.86	1.25	0.88	0.49	0.27
1.75 V	16.7	10.8	8.33	4.63	2.80	1.22	0.85	0.48	0.26
1.80 V	14.8	10.3	7.57	4.29	2.61	1.19	0.84	0.48	0.26
1.85 V	13.1	9.78	6.78	3.93	2.53	1.17	0.84	0.37	0.26

### Constant Power Discharge Ratings - watts at 25°C

F.V / Time	5 MIN	10 MIN	15 MIN	30 MIN	1 HR	3 HR	5 HR	10 HR	20 HR
1.60 V	40.0	26.0	20.0	11.6	6.50	2.53	1.72	0.97	0.51
1.67 V	38.7	25.4	19.7	11.4	6.43	2.52	1.71	0.97	0.51
1.70 V	37.1	25.0	19.2	11.2	6.36	2.50	1.71	0.96	0.50
1.75 V	34.9	24.2	18.6	10.9	6.26	2.48	1.70	0.96	0.50
1.80 V	30.3	22.2	17.8	10.6	6.06	2.43	1.68	0.94	0.49
1.85 V	28.6	20.6	17.0	10.1	5.92	2.39	1.66	0.94	0.49



CE 1188



MH 29410

**Tel** | +44 (0) 151 523 2777  
**Fax** | +44 (0) 151 523 0855  
**E-mail** | info@ultracell.co.uk  
**Web** | www.ultracell.co.uk